

MRK.	DATE	REVISION	SIGN
△			

P.C.B LAND PATTERN

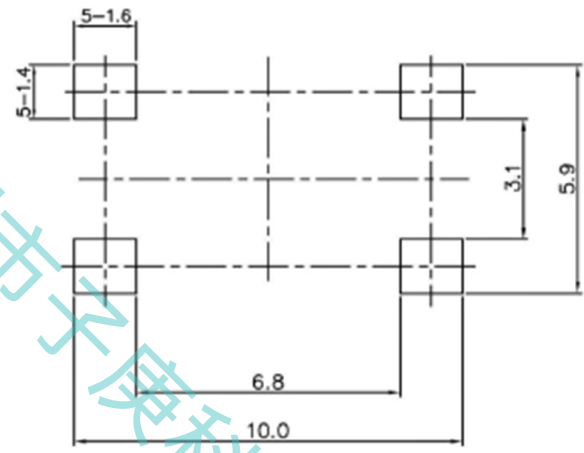

CIRCUIT DIAGRAM

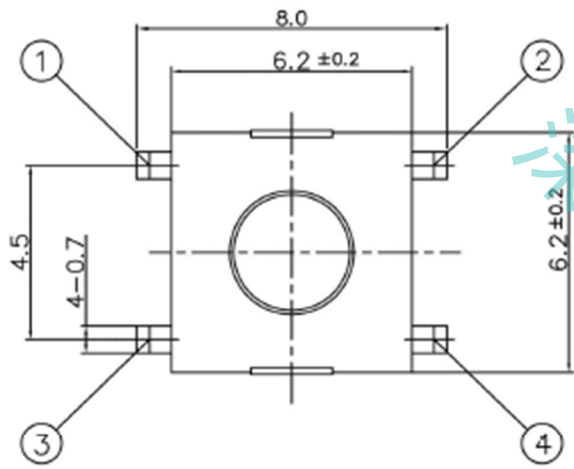
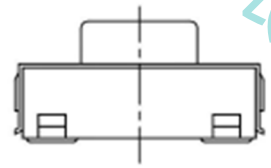
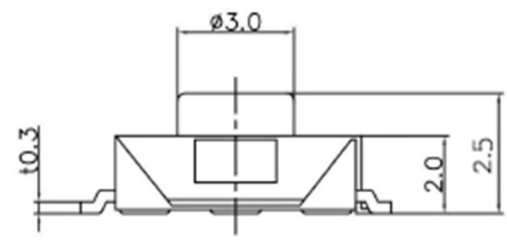
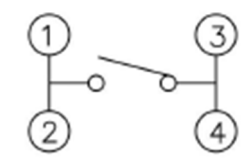

SPECIFICATION

1. RATING : DC 12V 50mA
2. TRAVEL : 0.25±0.1mm
3. CONTACT RESISTANCE : 100mΩ MAX.
4. BOUNCE : 10m SEC MAX.
5. OPERATING FORCE : 160±50gf
6. LIFE CYCLES : 80,000 CYCLE

01	-	-	-	1	-
NO.	DESCRIPTION	MATERIAL	COLOR/FINISH	Q.TY	VENDOR
W.J.LEE	J.P.ROH	K.LLEE	TACT SWITCH		
			G.TOL ±0.1	TITLE	SHEET
			UNIT mm	SCALE 4:1	
			SIZE A4	MODEL BSD-STP1125B	
 深圳市子庚科技有限公司			DRAW NO.		1/1